



OPERATING INSTRUCTIONS

MADE IN USA

5200 RICHMOND RD.

PHONE : 800-253-9726

Operating Instructions

WARNING!

Do not operate any Viking Air Tools, Inc. tool until you have read these operating instructions and do not discard these instructions for the life of the tool. While operating Viking Air Tools, Inc. tools always wear approved eye and ear protection. When dust is present always wear an approved respirator. Avoid prolonged exposure to tool vibration. Always keep hands, fingers, hair, clothing, and jewelry away from the tool's moving parts. Never operate a Viking Air Tools, Inc. tool beyond the recommended air pressure. Always use appropriately rated and approved tooling while operating Viking Air Tools, Inc. tools.

PUTTING A VIKING AIR TOOLS, INC. TOOL INTO SERVICE

Read and comprehend these operating instructions in their entirety before operating any Viking Air Tools, Inc. product.

Unpack the Viking Air Tools, Inc. product, carefully inspect for any damage that may have occurred during transit. Make sure any loose fittings, bolts, etc., are tightened before putting this product into service.

WARNING! (Never use damaged Viking Air Tools, Inc. Tools)

Use TABLE I to select appropriate tooling and protective wear for use with Viking Air Tools, Inc. tools. Use only approved protective wear and tooling with Viking Air Tools, Inc. tools. Consult tooling and protective wear manufacturer for the selection of appropriate tooling and protective wear for use with Viking Air Tools, Inc. tools. **WARNING!** (Never use unapproved or inappropriate tooling or protective wear)

Insure the air system the Viking Air Tools, Inc. tool is being attached to is safe and regulated to the recommended pressure according to TABLE I. **WARNING!** (Never exceed the pressure rating for any component in the air system) Exceeding this pressure recommendation can reduce the life of Viking Air Tools, Inc. tools, void the warranty, and create hazardous operating conditions.

Always disconnect the Viking Air Tools, Inc. tool from the air supply before changing tooling, attachments, adapters, and during periods when the tool is not in use. **CAUTION!** (Never leave a Viking Air Tools, Inc. tool attached to the air system when not in use)

Use TABLE I to select an appropriate adapter to connect the Viking Air Tools, Inc. tool to the air system. Wrap the threads of the appropriate adapter with Teflon tape, insert adapter into air inlet, hand start adapter into air inlet, and tighten until there is no leakage.

Cover body parts with approved protective wear. Attach Viking Air Tools, Inc. tool to air system. Use a mixture of soapy water and apply at adapter threads to test for leaks. If there are air leaks remove tool from air system, retighten adapter and repeat test. **CAUTION!** (Never over tighten adapter as over tightening may damage the tool's air inlet)

At the factory Viking Air Tools, Inc. tools are preloaded with excess amounts of lubricants (pneumatic oil and grease). These excess amounts are required to cover transit and slow inventory turn periods. Secure a shop towel, cover body parts with protective wear, connect tool to air supply, operate the Viking Air Tools, Inc. tool for five minutes, stop tool, disconnect tool from air system, and wipe excess oil from tool. Repeat this procedure until excess lubricants have been removed.

Congratulations, your Made in the USA Viking Air Tools, Inc. tool is now ready for use.

APPLICATION & USE

Refer to TABLE II to determine the various types of safe applications for your Viking Air Tools, Inc. tool.

HANDLING

Avoid dropping, or other abusive treatment of your Viking Air Tools, Inc. tool as it could damage the product or void the warranty. Reasonable care should be exercised while handling all Viking Air Tools, Inc. products. Never carry your air tool by an attached hose.

Do not depress trigger while connecting or disconnecting a tool to or from the air system. Release the pressure from the air system before connecting to or disconnecting from the air system.

Before storage of a Viking Air Tools, Inc. tool, disconnect the tool from the air system, place five to ten drops of oil in the tool's air inlet, reconnect to air system, operate the tool for thirty seconds, disconnect from the air system, and store.

ASSEMBLY & DISMANTLING

Refer to TABLE III for assembly and dismantling instructions. **CAUTION!** (Never assemble or dismantle without first removing your Viking Air Tools, Inc. tool from the air supply. Never use inappropriate or unapproved tooling or accessories.)

MAINTENANCE & ADJUSTMENT

Refer to TABLE IV for all maintenance and adjustment frequencies and instructions. **CAUTION!** (Never perform maintenance or adjustments unless the Viking Air Tools, Inc. Tool is disconnected from the air system.)

TRAINING INSTRUCTIONS

Only qualified and trained hand tool operators with knowledge of the safe operation of air tools should operate Viking Air Tools, Inc. tools. **CAUTION!** (Never operate a Viking Air Tools, Inc. tool without prior training or experience in the safe operation of pneumatic hand tools.)

TOOLING & ACCESSORIES FOR VIKING AIR TOOLS, INC. TOOLS

Use only approved and appropriate tooling and accessories with Viking Air Tools, Inc. tools. Viking Air Tools, Inc. offers a complete line of accessories for its product line. We recommend only our accessories for use with Viking Air Tools, Inc. tools. Consult tooling manufacturers and refer to TABLE I for the selection of approved and appropriate tooling. **CAUTION!** (Never use unapproved or inappropriate tooling or accessories with Viking Air Tools, Inc. tools.)

TROUBLESHOOTING - PROBLEMS

Refer to TABLE V for a complete troubleshooting and problem solving guide. In addition, the following four explanations are provided and should answer 90% of all troubleshooting and problem questions.

Manual Start Assistance

Problem: Manual start assistance may be required on very rare occasions. These occasions are rare and are inherent to the design of, not the quality of the tool. A manual start position can be reached on many types of air tools from most, if not all, manufacturers. Two examples are, steady state is reached without extended rotor vanes or rotating valves coming to rest at dead center timing points.

Corrective Action: First disconnect tool from air system. For rotating motorized tools - turn rotor by gently turning chuck or for piston motorized tools - move piston by gently pushing sanding shoe. Reconnect tool to the air system and begin use.

Stalls or Degradation of Performance

Problem: The air tool loses power or stalls while using. These situations sometimes occur when inappropriate or high viscosity oil has been used to lubricate the air tool or because of dirt build up in the air tool motor.

Corrective Action: First disconnect tool from air system. Thin the oil or remove dirt from motor by applying mineral spirits through the air inlet and manually exercise the air motor, continue this process until the motor moves without resistance, reapply Viking Air Tools, Inc. pneumatic tool oil, connect tool to air system, and begin use.

Resistance Pressure Start Up Failures

Problem: The air tool will not start when the start trigger is depressed. These situations sometimes occur when resistance pressure is applied at start up thereby creating a blow by condition.

Corrective Action: Remove resistance pressure and reapply air source by depressing trigger without downward pressure applied to tool.

Leaks

Problem: The air tool sounds like it is leaking. Often times this sound is normal during the operation of the tool. During operation of air motors excess air is vented to either the front or rear of the tool. This is inherent to the design of air motors and is not related to the quality of the tool. Sometimes this can be an abnormal condition resulting from incorrect installation of air system adapters or other leaking air system components.

Corrective Action: Viking Air Tools, Inc. tools are leak tested at the factory and therefore should reach the consumer without leaks. However, when the user adapts his tool to the air system he is required to supply and install a plug adapter. If this plug adapter is incorrectly or loosely installed or is the incorrect adapter then the connection will leak at the tools air inlet. Refer to **PUTTING A VIKING AIR TOOLS, INC. TOOL INTO SERVICE** and follow the instructions for adapter selection and installation.

Selection of Appropriate Protective Wear

WARNING: Consult TABLE I of these instructions and the protective wear manufacturer specifications to select appropriate protective wear. The protective wear chosen should exceed the protection required by TABLE I.

WARNING: Anti Vibration gloves should be worn while using tools that have a value of ">2.5m/s" in the Vibration column of TABLE I.

WARNING: When selecting an appropriate respirator insure it is rated to filter the size of the dust particles being generated by the use of your air tool.

WARRANTY

We warrant this tool to be free from defects in original workmanship and material and that it was tested and inspected by us before shipping. Our obligation to the original purchaser for any default under this warranty or for any fault or negligence in manufacturing is limited to repairing or replacing at our expense, not including shipping charges. The return shipping charge for such defective merchandise, if returned by original purchaser within one year after date of purchase, shall be prepaid, provided this defect is not the result of misuse or abnormal operation, or purchaser has disassembled this tool in attempting to repair, or purchaser has defaced tool by engraving, or purchaser has not lubricated as specified in the instruction manual, or maintained the tool under normal operating conditions at all times.

The Viking Air Tools, Inc. tool policy is one of continued product improvement. Therefore, we reserve the right to make changes in design and/or construction at any time without incurring any obligation for tools previously sold.

VIKING AIR TOOLS, INC.

5200 RICHMOND ROAD ~ CLEVELAND ~ OHIO ~ 44146 USA

800-253-9726 PHONE

216-831-9573 FAX

Table 1 Specifications

Tool Category	Model	SPM	RPM	BPM	CFM	HP	NOISE (dba)	WEIGHT (In lbs)	HOSE (min.)	VIBRATION M/S2	
Sanders	V100	2400			4	N/A	91	7.75	3/8"	>2.5	
	V101	2400			4	N/A	89	6.5	3/8"	>2.5	
	V102	2400			4	N/A	91	7.75	3/8"	>2.5	
	V103	2400			4	N/A	78	4.5	3/8"	>2.5	
	V200			10000		4	N/A	78	4.5	3/8"	>2.5
	V201			900		4	N/A	87	5.5	3/8"	>2.5
	V202			10000		4	N/A	87	5.5	3/8"	>2.5
	V203			900		4	N/A	89	6.5	3/8"	>2.5
	V320			20000		4	0.5	84	2.5	3/8"	<2.5
	V716S			0 - 6,000		4	1	82	5	3/8"	>2.5
Polisher	V716P		0 - 4,000		8	1	82	6	3/8"	<2.5	
Die Grinders	V323		20000		4	0.5	82	2	3/8"	2.5	
	V324		20000		4	0.5	82	2	3/8"	<2.5	
	V361		20000		4	0.4	86	1	3/8"	2.5	
	V362		20000		4	0.4	86	1	3/8"	2.5	
	V363		20000		4	0.4	86	1.25	3/8"	2.5	
	V364		15000		4	0.4	86	1.25	3/8"	2.5	
Drills	V322		20000		4	0.5	84	2.5	3/8"	<2.5	
	V323		20000		4	0.5	84	2.5	3/8"	<2.5	
	V341		2400		4	0.5	82	3	3/8"	2.5	
	V342		2400		4	0.5	82	3	3/8"	2.5	
	V343		500		4	0.5	82	3	3/8"	2.5	
	V344		500		4	0.5	84	4.5	3/8"	2.5	
	V345		1200		6	1	84	3	3/8"	<2.5	
Cutting Tools	V325		20000		4	0.5	92	2.5	3/8"	<2.5	
	V316	1300			6	N/A	86	3.5	3/8"	<2.5	
Hammers	V833			3000		N/A	98	4.25	3/8"	2.5	
	V834			2100		N/A	98	4.5	3/8"	2.5	
Needle Scaler	V835			4400	4	N/A	92	4.75	3/8"	>2.5	
Impact Wrench	V944		9000		4	N/A	86	7.25	3/8"	<2.5	
	V944-2		9000		4	N/A	86	7.25	3/8"	<2.5	
Dustless Sanding System	V701					1.5	83	67	3/8"	<2.5	
	V701E					1.5	83	67	3/8"	2.5	
Hose Reel	V855					N/A	N/A	12	3/8"	<2.5	
Air Lights	V2000		20000		3	N/A	78	0.5	3/8"	2.5	
Air Ratchets	V755		250		4	0.4	92	1.25	3/8"	2.5	
	V756		200		4	0.5	95	2.125	3/8"	2.5	
	V757		180		4	0.5	95	3	3/8"	2.5	
Tire Buffer	V321		20000		4	N/A	92	2.5	3/8"	<2.5	

Table 1 Continued

Tool Category	Model	MAX. PRESSURE (PSI)	ADAPTER (size)	CHUCK / COLLET (size)	TOOLING INFORMATION
Sanders	V100	90-100	1/4"		Paper Size 2 3/4" X 17 1/2"
	V101	90-100	1/4"		Paper Size 2 3/4" X 11"
	V102	60	1/4"		Paper Diameter 6"
	V103	80	1/4"		Paper Diameter 8"
	V200	90-100	1/4"		Paper Diameter 3" or 5"
	V201	90-100	1/4"		Paper Size 2:3/4" X 17 1/2"
	V202	60	1/4"		Paper Diameter 6"
	V203	80	1/4"		Paper Diameter 8"
	V320	90-100	1/4"		Paper Size: 2 3/4" X 11"
V716S	90-100	1/4"		Paper Diameter 7"	
Polisher	V716P	90-100	1/4"		Buffing Pad Size 7"
Die Grinders	V323	90-100	1/4"	1/4"	Must Be Rated > RPM Specified
	V324	90-100	1/4"	1/4"	Shank < Chuck Size
	V361	90-100	1/4"	1/4"	Must Be Rated > RPM Specified
	V362	90-100	1/4"	1/4"	Must Be Rated > RPM Specified
	V363	90-100	1/4"	1/4"	Must Be Rated > RPM Specified
	V364	90-100	1/4"	1/4"	Must Be Rated > RPM Specified
Drills	V322	90-100	1/4"	1/4"	Shank < Chuck Size
	V323	90-100	1/4"	1/4"	Shank < Chuck Size
	V341	90-100	1/4"	1/4"	Shank < Chuck Size
	V342	90-100	1/4"	1/4"	Shank < Chuck Size
	V343	90-100	1/4"	1/2"	Shank < Chuck Size
	V344	90-100	1/4"	1/2"	Shank < Chuck Size
	V345	90-100	1/4"	3/8"	Shank < Chuck Size
Cutting Tools	V325	90-100	1/4"		2 7/8" Cutting Wheel
	V316	90-100	1/4"		3" to 5" Metal Cutting or Scroll Blades 14 to 32 TPI
Hammers	V833	90-100	1/4"		Accessories must have .680" shank diameter
	V834	90-100	1/4"		Accessories must have .680" shank diameter
Needle Scaler	V835	90-100	1/4"		NVA
Impact Wrench	V944	90-100	1/4"		Impact Rated Sockets
	V944-2	90-100	1/4"		Impact Rated Sockets
Dustless Sanding System	V701	90-100	1/4"		Use with Dustless Conversion Kits
	V701E	90-100	1/4"		Use with Dustless Conversion Kits
Hose Reel	V855	90-100	1/4"		NVA
Air Lights	V2000	90-100	1/4"		NVA
Air Ratchets	V755	90-100	1/4"		
	V756	90-100	1/4"		
	V757	90-100	1/4"		
Tire Buffer	V321	90-100	1/4"		Must Be Rated > RPM Specified

Table II
Application and Use

Tool Category	Model	Description
Sanders	V100 V101 V102 V103 V200 V201 V202 V203 V320 V716S	Sanding metals, wood, body filler, plastic, contour, level, special fit or smooth Select appropriate tooling from Table I.
Polisher	V716P	Polishing metals, wood, plastic, and painted surfaces to a high luster. Select appropriate tooling from Table I.
Die Grinders	V323 V324 V361 V362 V363 V364	Grinding metals, welds, etc. Used to remove burrs, fabricate, make special fits. Select appropriate tooling from Table I.
Drills	V322 V323 V341 V342 V343 V344 V345	Drilling of metals, wood, plastics, (excluding hardened steel and exotic metals) to desired size and depth. Select appropriate tooling from Table I.
Cutting Tools	V325 V316	Sawing and cutting metal, wood, plastic, etc. to desired lengths, widths, shapes and sizes. (Excluding hardened steel and exotic metals.) Select appropriate tooling from Table I.
Impact Wrenches	V944 V944-2	Used for tightening and loosening of bolts and studs 1/2" bolt capacity. Select appropriate tooling from Table I.
Air Lights	V2000	A source of light that can be used in conjunction with any air tool.
Hammers	V833 V834	Heavy duty chipping applications, i.e. foundries, shipyards, mining. Tamping dirt. Select appropriate tooling from Table I.
Needle Scaler	V835	Used for the peening of metals and in the removal of rust, welding slag, barnacles, etc. Select appropriate tooling from Table I.
Dustless Sanding System	V701 V701E	Removes dust created by sanding when used in conjunction with dustless sanders. Select appropriate tooling from Table I.
Air Hose Reel	V855	Keeps air hose neatly out of the way. Holds 100' of 5/8" or 50' of 1" hose. Select appropriate tooling from Table I.
Tire Buffer	V321	Smoothing inside of tires so that patches seal properly
Air Ratchets	V755 V756 V757	Used for tightening and loosening of bolts and studs 3/8" bolt capacity.

*Table III
Assembly and Dismantling*

Tool Category	Model	Description
Sanders	V100 V101 V102 V103	Remove shoe from box, insert shoe bolts or studs through holes in carrier, apply nuts and washer, then tighten. Clip Type Shoe: raise front and rear clips, attach sandpaper, and lower clips. Pressure Sensitive Shoe: remove backing from sandpaper insert edge into the slot at the front of the sanding pad and press paper onto pad from front to back. Velcro Shoe: line edge of sandpaper with edge of pad and press into place.
	V200 V201	Remove pad from box, thread onto sander. Remove backing from sandpaper and press onto pad. To operate as a standard disc sander, lock the rotor shaft to the sanding head by pushing in on the ring at the point of the dimple. To activate the Random Orbital Action, unlock the head from the rotor shaft by pulling out the ring at the point of the two dimples.
	V202 V203	Remove backing from sand paper and press onto pad.
	V320 V716S	Remove locknut, apply sandpaper to pad, insert nut and tighten.
	Polisher	V716P
Die Grinders	V323 V324 V361 V362 V363 V364	Remove collet nut with wrench provided. Install proper collet insert. Replace nut. Insert desired bit, tighten with wrench.
Drills	V322 V323 V341 V342 V343 V344 V345	Loosen chuck with supplied chuck key or wrench, insert proper drill bit, tighten. Thread drill bit into tool snugly.
Cutting Tools	V325 V316	Loosen both set-screws, install proper saw blade. Tighten both set screws evenly. Remove bolt and/or washer, install proper blade, reinstall bolt and/or bolt and washer.
Tire Buffer	V321	Check buffing wheel lock nut.
Air Ratchets	V755 V756 V757	Depress lockpin to install and remove socket.
Air Lights	V2000	Connect to tool using coupler.
Impact Wrenches	V944 V944-2	Remove provided lubricator from box and install in the air inlet of tool. Tighten. Depress pinlock, install proper socket for application.
Hammers	V833 V834	Remove retainer spring, install proper chisel or punch for application. Reinstall retainer spring.
Needle Scaler	V835	No assembly required
Air Hose Reel	V855	Remove Swivel Assembly from box. Connect Swivel to Air Inlet on side of Hose Reel. Remove Handle from crank, attach handle on outside of crank.
Dustless Sanding Systems	V701 V701E	Connect and check air inlet, power cord, and switch.

*Table IV
Maintain and Adjustments*

Tool Category	Model	Description	
Sanders	V100 V101 V102 V103 V200 V201 V202 V203	Check all nuts, bolts, and screws daily, tighten as needed. Oil daily at air inlet.	
	V716S	Check all screws daily, tighten as needed. Oil daily at air inlet. Grease monthly at grease fitting.	
	V320	Check locknut daily, tighten as needed. Oil daily at air inlet.	
Polisher	V716P	Check all screws daily, tighten as needed. Oil daily at air inlet. Grease monthly at grease fitting.	
Die Grinders	V323 V324 V361 V362 V363 V364	Check lock nut, tighten as needed. Oil daily at air inlet.	
	V341 V342 V343 V344 V345	Check housing, tighten as needed. Oil daily at air inlet. Grease monthly at grease fitting.	
		V322 V323	Check lock nut, tighten as needed. Oil daily at air inlet.
		V325	Check Locknut and all screws daily. Tighten as needed. Oil daily at air inlet.
	Cutting Tools	V316	Insure barrel is tight prior to each use, tighten as needed. Oil daily at air inlet. To increase or decrease stroke of tool remove rear barrel, adjust rear locknut, reinstall barrel. To adjust chuck and guard position loosen guard screw, remove guard, loosen chuck locknut, turn chuck to desired position and tighten locknut. Reinstall guard in same position as the chuck and tighten guard screw.
Tire Buffer	V321	Check lock nut, tighten as needed. Oil daily at air inlet.	
Air Ratchets	V755 V756 V757	Check lock nut and housing, tighten as needed. Oil daily at air inlet.	
	V2000	Check all connections, hoses, bulbs, and regulators.	
	Air Lights		
Impact Wrenches	V944 V944-2	Check all screws and bolts daily, tighten as needed. Oil daily at air inlet. Grease monthly at grease fitting.	
	V833 V834	Check retainer spring, replace as needed. Oil daily at air inlet.	
Hammers	V835	Check screws daily, tighten as needed. Check needles for wear, replace as needed. Oil daily at air inlet.	
Needle Scaler	V855	Check screws daily, tighten as needed. Check needles for wear, replace as needed. Oil daily at air inlet.	
Air Hose Reel	V701 V701E	Check air inlet, crank and handle screw, tighten as needed.	
Dustless Sanding Systems		Check air inlet, power cord, and switch. Oil daily at air inlet.	

Table V
Troubleshooting and Problem Solving

Symptom	Possible Causes	Corrective Action
Tool runs slowly	Low air pressure	Check compressor
	Dirt in inlet screen	Clean screen
	Dirt or thick oil build up	Flush with mineral spirits (Read TROUBLESHOOTING PROBLEMS)
	No oil in tool	Oil through air inlet
	Leaking air system	Check all connections, hoses and regulators
	Air supply hose and/or piping is too small	Enlarge supply lines
	Air compressor is too small	Enlarge compressor capacity
	Air system regulator is adjusted to a low pressure setting	Adjust regulator to appropriate pressure setting
	Insufficient grease	Grease tool (gear driven tools only)
Water blows out of tool	Water in air tank	Drain and install air dryer
	Water in air pipes or hoses	Drain and install air dryer
Tool Vibrates excessively	Loose nuts or bolts	Check and tighten all nuts and bolts
	Damaged or bent components	Check and replace
Tool will not run	(Read TROUBLESHOOTING PROBLEMS)	(Read TROUBLESHOOTING PROBLEMS)
	Air system problem	Check air system and repair as required
Tool stalls	(Read TROUBLESHOOTING PROBLEMS)	(Read TROUBLESHOOTING PROBLEMS)
I hear air leaking	(Read TROUBLESHOOTING PROBLEMS)	(Read TROUBLESHOOTING PROBLEMS)
	Air system leaks	Check air system for leaks and repair as needed
Tool will not start with pressure applied	(Read TROUBLESHOOTING PROBLEMS)	(Read TROUBLESHOOTING PROBLEMS)



VIKING V101 TIMING PROCEDURE

STEP 1

Disassemble tool, remove six screws from the side straps, remove side straps, remove carrier, then inspect all gears to make sure that they are not chipped, worn, etc.

STEP 2

Lay the tool on its side with the knob to the left and the handle to the right. Install the actuator gear into the center hole of the body; make sure that the actuator gear is properly engaged by being flush with the body. Turn the actuator gear so that both timing marks line up (9 o'clock position).

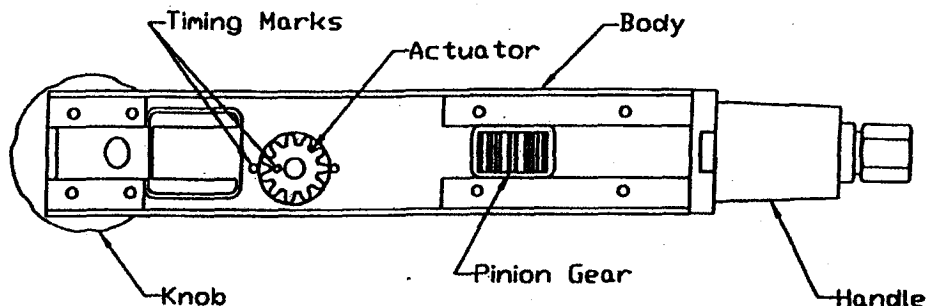

STEP 3

Make sure that the pinion gear turns freely in each direction. Then rotate the pinion gear towards the center of the tool until it stops. Then rotate the gear in the opposite direction until the next tooth is centered. Rotate the pinion gear in the same direction, four more teeth. The pinion gear is now centered.

STEP 4

Locate the center valley of the rack gear, located on the carrier. While aligning this valley with the center tooth of the pinion gear, also align the center of the actuator rack gear with the center tooth of the actuator gear. Use extreme care not to move any of the previously timed gears on the body of the tool.

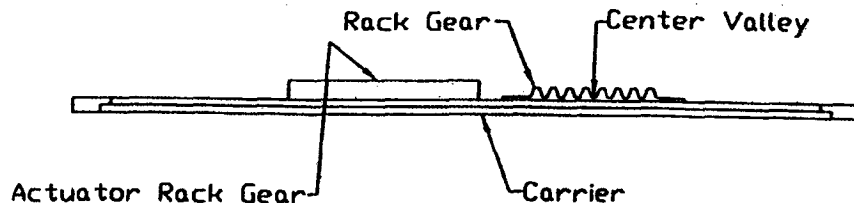

STEP 5

Place the side strap onto the tool, align all three holes. Using MM115 thread locker, from the center out insert and tighten the screws. Flip the tool over and do the same to the other side. Use extreme care not to move the carrier in this operation. Make sure that the carrier moves freely and is close fitting. A small hammer may be used to lightly tap the side straps until the carrier is close fitting, but not tight. If this does not work, repeat, beginning with step one through four.

Installation Instructions

Viking V600 & V603

Dust Extraction Conversion Kit for V100 & V101

TOOLS AND MATERIALS REQUIRED:

#2 Phillips screwdriver, 3/8" - 7/16" wrench, 1/8" and 5/32" allen wrenches and a dry cloth.

Step 1. Remove old sanding pad from the tool to be converted to the dust extraction sander.

Step 2. Clean the bottom of sanding shoe carrier. **Important:** Make sure that carrier is straight.

Step 3. Attach dust extracting shoe (1), extraction opening (1A) on left side of tool, with the provided bolts (2), washers (3) and nuts (4). **For your safety:** Place bolt heads through the top of carrier as shown to reduce pinch hazard on carrier.

Step 4. Remove screws from the side of the sander body where indicated by arrows. Clean side strap surface.

Step 5. Place the tool on a flat surface (shoe down) and install dust extraction tube (5) with the provided screws (6).

Step 6. With light pressure, push down on extraction tube while tightening screws. The extraction tube will be in light contact with shoe surface. No visible gap should be apparent between tube and shoe. If a gap exists, push down a little harder while tightening the screws.

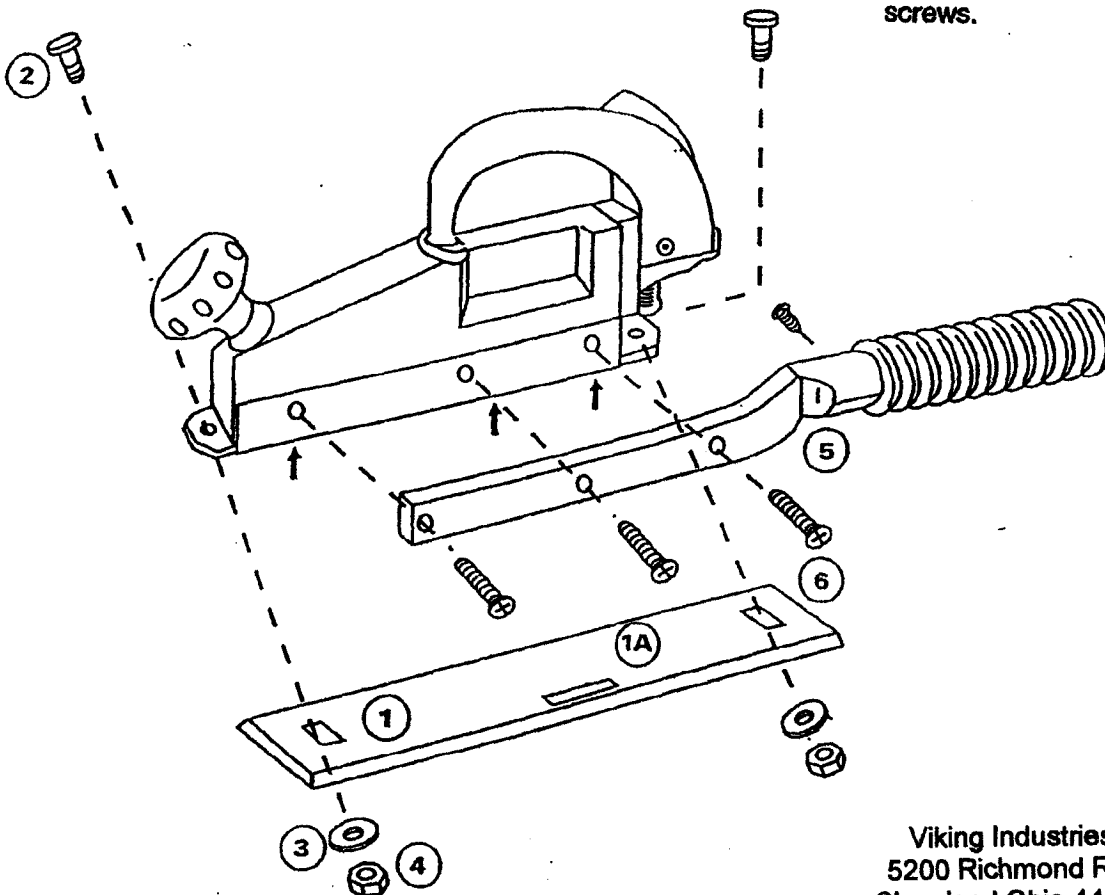

Viking Industries
5200 Richmond Rd.
Cleveland Ohio 44146
800-253-9726
Fax 216-831-9573